

cintac.cl



Catálogo General  
**Productos  
y Sistemas**

ABRIL-2025

**CINTAC**® simplificamos tu mundo

# CINTAC®

Cintac es líder en la fabricación y comercialización de sistemas constructivos, con la más amplia oferta de productos de acero, atiende las necesidades del mercado la construcción e industria.

Con presencia en Chile, Perú y gran parte de Latinoamérica, Cintac ofrece al mercado sus líneas de tubos, perfiles, cañerías, planchas, cubiertas, revestimientos, elementos estructurales y de infraestructura, con propuestas innovadoras y un equipo técnico de excepción.



## Ángulos NCh 3576

### Especificaciones Generales

<b>Largo normal:</b>	6 mts. Otros largos previa consulta.	
<b>Recubrimiento:</b>	Negro.	
<b>Extremos:</b>	Lisos de máquina.	
<b>Calidades normales:</b>	ASTM A36 / NCh 3576	
<b>Otras dimensiones:</b>	A pedido, previa consulta a CINTAC.	

Dimensiones nominales			Peso teórico	SAP
A	B	e	P	
mm	mm	mm	Kg/m	
20	20	2	0,58	43000000
20	20	3	0,83	43000001
25	25	2	0,73	43000002
25	25	3	1,06	43000003
30	30	2	0,89	43000004
30	30	3	1,3	43000005
40	40	2	1,2	43000006
40	40	3	1,77	43000007
40	40	4	2,31	43000008
50	50	2	1,52	43000009
50	50	3	2,24	43000010
50	50	4	2,93	43000011
50	50	5	3,6	43000012
65	65	3	2,95	43000013
65	65	4	3,88	43000014
65	65	5	4,78	43000015
80	80	4	4,82	43000016
80	80	5	5,96	43000017
80	80	6	7,07	43000018
100	100	4	6,07	43000019
100	100	5	7,53	43000020
100	100	6	8,96	43000021

**Notas:**

- Los perfiles canales y costaneras se fabrican según norma interna ET- 11/MA-7-2
- También se fabrica a pedido los tubulares que se obtienen de la unión, mediante dos cordones de soldadura, de los perfiles canales.

## Canales NCh 3576

### Especificaciones Generales

<b>Largo normal:</b>	6 mts. Otros largos previa consulta.	
<b>Recubrimiento:</b>	Negro.	
<b>Extremos:</b>	Lisos de máquina.	
<b>Calidades normales:</b>	ASTM A36 / NCh 3576	
<b>Otras dimensiones:</b>	A pedido, previa consulta a CINTAC.	

Dimensiones nominales			Peso teórico	SAP
A	B	e	P	
mm	mm	mm	Kg/m	
50	25	2	1,47	43000022
50	25	3	2,12	43000023
80	40	2	2,41	43000024
80	40	3	3,54	43000025
80	40	4	4,61	43000026

Dimensiones nominales			Peso teórico	SAP
A	B	e	P	
mm	mm	mm	Kg/m	
100	50	2	3,04	43000027
100	50	3	4,48	43000028
100	50	4	5,87	43000029
100	50	5	7,20	43000030
125	50	2	3,43	43000031
125	50	3	5,07	43000032
125	50	4	6,65	43000033
150	50	2	3,82	43000034
150	50	3	5,66	43000035
150	50	4	7,44	43000036
150	50	5	9,17	43000037
150	75	3	6,83	43000038
150	75	4	9,01	43000039
150	75	5	11,3	43000040
200	50	2	4,61	43000041
200	50	3	6,83	43000042
200	50	4	9,01	43000043
200	50	5	11,13	43000044
200	75	3	8,01	43000045
200	75	4	10,58	43000046
200	75	5	13,09	43000047
250	50	3	8,01	43000048
250	50	4	10,58	43000049
250	75	4	12,15	43000050

Costaneras NCh 3576

Especificaciones Generales

<b>Largo normal:</b>	6 mts. Otros largos previa consulta.	
<b>Recubrimiento:</b>	Negro.	
<b>Extremos:</b>	Lisos de máquina.	
<b>Calidades normales:</b>	ASTM A36 / NCh 3576	
<b>Otras dimensiones:</b>	A pedido, previa consulta a CINTAC.	

Dimensiones nominales				Peso teórico	SAP
A	B	C	e	P	
mm	mm	mm	mm	kg/m	
80	40	15	2	2,78	43000051
80	40	15	3	4,01	43000052
100	50	15	2	3,4	43000053
100	50	15	3	4,95	43000054
125	50	15	2	3,8	43000055
125	50	15	3	5,54	43000056
150	50	15	2	4,19	43000057
150	50	15	3	6,13	43000058
150	50	15	4	7,97	43000059
200	50	15	3	7,31	43000060

Tubos NCh 3518 /Tubos ASTM 500

Especificaciones Generales

<b>Largo normal:</b>	6 mts. Otros largos previa consulta.	
<b>Recubrimiento:</b>	Negro.	
<b>Extremos:</b>	Lisos de máquina.	
<b>Calidades normales:</b>	NCh 3518 / ASTM A36 - SAE 1010- SAE 1008	
<b>Otras dimensiones:</b>	A pedido, previa consulta a CINTAC.	

Designación	Espesor	Peso teórico	SAP
Diámetro exterior	e	P	
D	mm	kg/m	
3/4"	1,5	0,65	34000126
3/4"	2	0,84	34000127
1"	1,5	0,88	34000128
1"	2	1,15	34000129
1 1/4"	1,5	1,12	34000130
1 1/4"	2	1,47	34000131
1 1/2"	1,5	1,35	34000132
1 1/2"	2	1,78	34000133
1 3/4"	1,5	1,59	34000134
2"	1,5	1,82	34000135
2"	2	2,41	34000136
2"	3	3,54	34000137
3"	2	3,66	34000138
3"	3	5,42	34000139
4"	2	4,91	34000140
4"	3	7,29	34000141
4"	4	9,63	34000142
5"	4	12,1	34000143
5"	5	15	34000144

Perfiles cuadrados NCh 3518 / ASTM A500

Especificaciones Generales

<b>Largo normal:</b>	6 mts. Otros largos previa consulta.	
<b>Recubrimiento:</b>	Negro.	
<b>Extremos:</b>	Lisos de máquina.	
<b>Calidades normales:</b>	NCh 3518 / ASTM A36 - SAE 1010- SAE 1008	
<b>Otras dimensiones:</b>	A pedido, previa consulta a CINTAC.	

Dimensiones nominales			Peso teórico	SAP
A	A	Espesor e		
mm	mm	mm	Kg/m	
15	15	1	0,42	34000069
15	15	1,5	0,59	34000070
20	20	1	0,58	34000071
20	20	1,5	0,83	34000072
20	20	2	1,05	34000073
25	25	1,5	1,06	34000074
25	25	2	1,36	34000075
30	30	1,5	1,3	34000076
30	30	2	1,68	34000077
40	40	1,5	1,77	34000079
40	40	2	2,31	34000080
40	40	3	3,3	34000081
50	50	1,5	2,24	34000082
50	50	2	2,93	34000083
50	50	3	4,25	34000084
50	50	4	5,45	34000085
50	50	5	6,56	34000086
75	75	2	4,5	34000087
75	75	3	6,6	34000088
75	75	4	8,59	34000089
75	75	5	10,48	34000090
100	100	2	6,07	34000091
100	100	3	8,96	34000092
100	100	4	11,73	34000093
100	100	5	14,41	34000094
100	100	6	16,98	34000095

Perfiles rectangulares NCh 3518 / ASTM A500

Especificaciones Generales

<b>Largo normal:</b>	6 mts. Otros largos previa consulta.	
<b>Recubrimiento:</b>	Negro.	
<b>Extremos:</b>	Lisos de máquina.	
<b>Calidades normales:</b>	NCh 3518 / ASTM 500	
<b>Otras dimensiones:</b>	A pedido, previa consulta a CINTAC.	

Dimensiones nominales			Peso teórico	SAP
A	B	Espesor e		
mm	mm	mm	Kg/m	
25	15	1,5	0,83	34000097
30	20	1	0,73	34000098
30	20	1,5	1,06	34000099
30	20	2	1,36	34000100
40	20	1,5	1,3	34000102
40	20	2	1,68	34000103
40	30	1,5	1,53	34000104
40	30	2	1,99	34000105
50	20	1,5	1,53	34000106
50	20	2	1,99	34000107
50	30	1,5	1,77	34000108
50	30	2	2,31	34000109
50	30	3	3,3	34000110
60	40	2	2,93	34000111
60	40	3	4,25	34000112
70	30	2	2,93	34000113
70	30	3	4,25	34000114
80	40	2	3,56	34000115
80	40	3	5,19	34000116
80	40	4	6,71	34000117
100	50	2	4,5	34000118
100	50	3	6,6	34000119
100	50	4	8,59	34000120
100	50	5	10,48	34000121
150	50	2	6,07	34000122
150	50	3	8,96	34000123
150	50	4	11,73	34000124
150	50	5	14,41	34000125

**TUBULARES GRANDES DIMENSIONES**

**Especificaciones Generales**

Largo normal:	6 y 12 mts. Según disponibilidad de stock
Calidad normal:	ASTM A500

**Cuadrados**

Dimensiones nominales			Peso teórico	SAP	
A	B	Espesor e		6 m	12 m
mm	mm	mm	Kg/m		
150	150	3	13,70	43002772	43002771
150	150	4	18,00	43002773	43002801
150	150	5	22,30	43002776	43002777
200	200	3	18,40	34000149	34000163
200	200	4	24,30	34000150	34000164
200	200	5	30,10	34000157	34000172

**Rectángulos**

Dimensiones nominales			Peso teórico	SAP	
A	B	Espesor e		6 m	12 m
mm	mm	mm	Kg/m		
150	100	3	11,3	34000182	34000195
150	100	4	14,9	34000174	34000187
150	100	5	18,3	34000175	34000188
200	100	3	13,72	43002779	43002780
200	100	4	18	43002774	43002802
200	100	5	22,3	43002807	43002808



## Ángulos Laminados

### Especificaciones Generales

<b>Largo Normal:</b>	6 mts. Según disponibilidad de stock
<b>Tolerancia:</b>	+ 2,5% en peso teórico
<b>Calidades normales:</b>	A270ES, ASTM A36 y comercial

Dimensiones	Espesor	Peso	SAP
h x b	e	P	
mm	mm	Kg/m	
20x20	3,00	0,88	36000385
25x25	3,00	1,12	36000386
25x25	5,00	1,78	36000387
30x30	3,00	1,36	43000486
30x30	5,00	2,18	43000487
40x40	3,00	1,84	36000382
40x40	4,00	2,42	43000480
40x40	5,00	2,97	43000488
50x50	3,00	2,33	43000489
50x50	4,00	3,06	43000481
50x50	5,00	3,77	43001284
50x50	6,00	4,47	43001490
65x65	5,00	4,97	43000491
65x65	6,00	5,91	43000492
65x65	8,00	7,73	36000388
65x65	10,00	9,49	43001851
80x80	6,00	7,34	43000485
80x80	8,00	9,63	43000483
80x80	10,00	11,9	43000478
100x100	6,00	9,26	43000493
100x100	8,00	12,2	43000484
100x100	10,00	15,0	43000494
100x100	12,00	17,8	36000384

**Barras Planas Laminadas Caliente**

**Especificaciones Generales**

<b>Largo Normal:</b>	6 mts. Según disponibilidad de stock
<b>Tolerancia:</b>	+ 2,5% en peso teórico
<b>Calidades normales:</b>	A270ES, ASTM A36 y comercial

Dimensiones	Espesor (mm)	Peso Teórico (kg/m)	SAP
20	3,00	0,471	43000498
20	5,00	0,790	43000499
25	3,00	0,590	43000500
25	5,00	0,980	43000501
25	10,00	1,960	43000503
32	3,00	0,750	43000504
32	5,00	1,260	43000505
32	6,00	1,510	43000506
38	3,00	0,895	43000507
38	5,00	1,490	43000508
50	3,00	1,180	43000509
50	5,00	1,960	43000510
50	6,00	2,360	43000511
50	8,00	3,140	43000512
63	5,00	2,470	43000513
63	6,00	2,97	43000514
75	5,00	2,94	43000515
75	6,00	3,53	43000516
75	10,00	5,89	43000517
100	5,00	3,930	43000519
100	6,00	4,710	43000520
100	8,00	6,280	43000521

## Cañería acero carbono ASTM A53 Grado A/B Schedule 40

## Especificaciones Generales

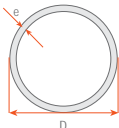
<b>Descripción:</b>	Cañería ASTM A53	
<b>Extremos:</b>	Biselados.	
<b>Material:</b>	Negro o galvanizado.	
<b>Formato:</b>	Largo comercial 6 m, largos especiales a pedido.	

Diámetro Nominal Pulg. (D)	Espesor mm (e)	Peso Teórico kg/m	SAP	
			Negras	Galvanizadas
			Sin Hilo	Sin Hilo
1/2"	2,77	1,27	34000033	34000231
3/4"	2,87	1,69	34000034	34000045
1"	3,38	2,50	34000035	34000046
1 1/4"	3,56	3,39	34000036	34000232
1 1/2"	3,68	4,05	34000037	34000047
2"	3,91	5,44	34000038	34000048
2 1/2"	5,16	8,63	34000039	34000233
3"	5,49	11,29	34000040	34000049
4"	6,02	16,07	34000041	34000050
6"	7,11	28,26	34000044	34000236

## Cañería acero carbono ISO 65

## Especificaciones Generales

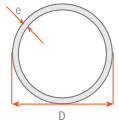
<b>Descripción:</b>	Cañería Serie Liviana II ISO 65.	
<b>Extremos:</b>	Biselados.	
<b>Revestimiento:</b>	Negro o galvanizado.	
<b>Formato:</b>	Largo comercial 6 m, largos especiales a pedido.	

Diámetro Nominal Pulg. (D)	Espesor mm (e)	Peso Teórico kg/m	SAP	
			Negras	Galvanizadas
			Sin Hilo	Sin Hilo
1/2"	2,00	0,95	34000051	34000060
3/4"	2,30	1,38	34000052	34000061
1"	2,60	1,98	34000053	34000062
1 1/4"	2,60	2,54	34000054	34000063
1 1/2"	2,90	3,23	34000055	34000064
2"	2,90	4,08	34000056	34000065
2 1/2"	3,20	5,71	34000057	34000066
3"	3,20	6,72	34000058	34000067
4"	3,60	9,75	34000059	34000068

**Planchas Gruesas**

**Especificaciones Generales**

<b>Espesores:</b>	6.00 a 100.00 mm.
<b>Anchos:</b>	2000 y 2440 mm.
<b>Largos:</b>	6.0 y 12.0 m. Largos especiales a pedido.
<b>Calidad:</b>	A36 - A515 - A572

Espesor mm	Peso Teórico kg/m <sup>2</sup>
6,00	48,00
8,00	64,00
10,00	80,00
12,00	96,00
14,00	112,00
16,00	128,00
18,00	144,00
20,00	160,00
22,00	176,00
25,00	200,00
32,00	256,00
38,00	304,00
50,00	400,00
65,00	520,00
75,00	600,00
100,00	800,00

**Planchas Diamantadas**

**Especificaciones Generales**

<b>Espesores:</b>	2.50 a 6.00 mm.
<b>Anchos:</b>	1000 mm.
<b>Largos:</b>	3.0 y 6.0 m. Largos especiales a pedido.
<b>Calidad:</b>	A786

Espesor mm	Peso Teórico kg/m <sup>2</sup>
2,5	21,25
3,0	25,5
4,0	34
5,0	42,5
6,0	51

**Laminados en Caliente**

**Especificaciones Generales**

<b>Espesores:</b>	2.00 a 12.00 mm.
<b>Anchos:</b>	1000 y 1500 mm.
<b>Largos:</b>	2.0 - 2.5 - 3.0 y 6.0m Largos especiales a pedido.
<b>Calidad:</b>	A36
<b>Formato entrega:</b>	A granel y bultos de 2000 Kg. aprox.

Espesor mm	Peso Teórico kg/m <sup>2</sup>
2,0	16
2,5	20
3,0	24
4,0	32
5,0	40
6,0	48
8,0	64
10,0	80
12,0	96

**Laminados en Frío**

**Especificaciones Generales**

<b>Espesores:</b>	0.40 a 1.9 mm.
<b>Anchos:</b>	1000 y 1500 mm.
<b>Largos:</b>	2.0 - 2.5 y 3.0 mts. Largos especiales a pedido.
<b>Calidad:</b>	SAE 1008.
<b>Formato entrega:</b>	A granel y bultos de 2000 Kg. aprox.

Espesor mm	Peso Teórico kg/m <sup>2</sup>
0,40	3,20
0,50	4,00
0,60	4,80
0,70	5,60
0,80	6,40
0,90	7,20
1,00	8,0
1,20	9,60
1,40	11,20
1,50	12,00
1,90	15,20

**Planchas Galvanizadas**

**Especificaciones Generales**

<b>Espesores:</b>	0.35 a 2.5 mm.
<b>Anchos:</b>	1000 y 1220 mm.
<b>Largos:</b>	2.0 - 2.5 - 3.0 m Largos especiales a pedido.
<b>Calidad:</b>	ASTM A653 G60
<b>Formato entrega:</b>	A granel y bultos de 2000 Kg. aprox.

Espeor mm	Largo mm	Descripción	Peso Teórico kg/m <sup>2</sup>	SAP
0,35	2000	PL 0.35X1000X2000 GLV REG SPNG	5,46	30016255
	2500	PL0.35X1000X2500 GLV REG SPNG	6,83	30016291
	3000	PL0.35X1000X3000 GLV REG SPNG	8,19	30016256
0,4	2000	PL 0.4X1000X2000 GLV REG SPNG	6,24	30016257
	2500	PL0.4X1000X2500 GLV REG SPNG A	7,80	30016292
	3000	PL 0.4X1000X3000 GLV REG SPNG	9,36	30016258
0,5	2000	PL 0.5X1000X2000 GLV REG SPNG	7,82	30016259
	2500	PL0.5X1000X2500 GLV REG SPNG A	9,78	30016293
	3000	PL0.5X1000X3000 GLV REG SPNG A	11,73	30016260
0,6	3000	PL 0.6X1000X3000 GLV REG SPNG	14,07	30016261
0,8	2000	PL0.8X1000X2000 GLV REG SPNG A	12,52	30016325
	2500	PL0.8X1000X2500 GLV REG SPNG A	15,65	30016782
	3000	PL 0.8X1000X3000 GLV REG SPNG	18,78	30016262
1	2000	PL 1X1000X2000 GLV REG SPNG A6	15,66	30016294
	3000	PL1X1000X3000 GLV REG SPNG A65	23,49	30016264
1,5	2000	PL1,5X1000X2000 GLV REG SPNG A	23,52	30016328
	2500	PL1.5X1000X2500 GLV REG SPNG A	29,40	30016789
	3000	PL 1.5X1000X3000 GLV REG SPNG	35,28	30016266

Todas las especificaciones señaladas están sujetas a confirmación por parte de Cintac. Consulte por otros espesores.

**Planchas Zinalum®**

**Especificaciones Generales**

<b>Espesores:</b>	0.35 a 0.80 mm.
<b>Anchos:</b>	1000 mm.
<b>Largos:</b>	2.0 y 2.5 y 3.0 m Largos especiales a pedido.
<b>Calidad:</b>	ASTM A792 -AZM 150

Espeor mm	Largo mm	Descripción	Peso Teórico kg/m <sup>2</sup>	SAP
0,35	2000	PL0.35X1000X2000 ZA A792	5,46	30016283
	2500	PL 0.35X1000X2500 ZA A792	6,83	30016300
	3000	PL0.35X1000X3000 ZA A792	8,19	30016284
0,4	2000	PL 0.4X1000X2000 ZA A792	6,26	30016045
	2500	PL 0.4X1000X2500 ZA A792	7,83	30016805
	3000	PL0.4X1000X3000 ZA A792	9,39	30016285
0,5	3000	PL0.5X1000X3000 ZA A792	11,73	30016286

## SISTEMA CONSTRUCTIVO TUBEST

### Sección Perfil Sigma

#### Especificaciones Generales

Tolerancias:	ET-16/MA-7-2
Largos Normales:	6, 7 y 8 m.
Extremos:	Lisos de máquina.

#### Sección Perfil Sigma H x es x Kg/m

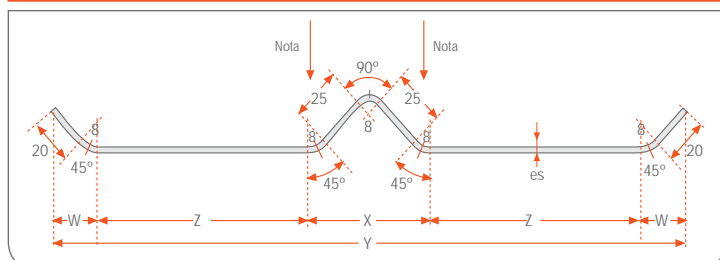

#### Sección Perfil Sigma Especial 250 x es x Kg/m

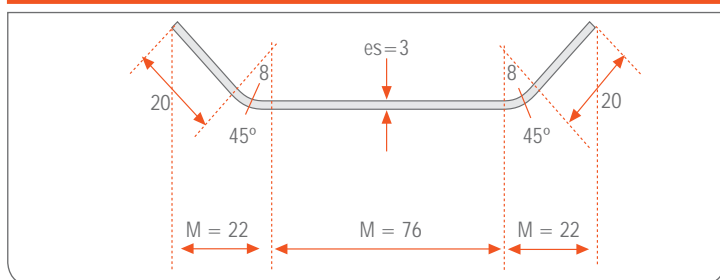

Se pueden fabricar Ohm con ancho hasta 400 mm. Solicite a Cintac mayor información.

Perfil	Dimensiones nominales		Peso	SAP		
	P. Comp.	Esp.		6 m	7 m	8 m
	H mm	e mm	P kg/m			
250x3	250	3	3,08	43000216	43001054	43001055
300x3	300	3	4,68	43000217	43001056	43001057
350x3	350	3	5,86	43000218	43001058	43001059
400x3	400	3	7,04	43000219	43001060	43001061
450x3	450	3	8,22	43000220	43001062	43001063
500x3	500	3	9,39	43000221	43001064	43001065
550x3	550	3	10,51	43000222	43001066	43001067

Sección Perfil Ohm

Especificaciones Generales

Tolerancias:	ET-16/MA-7-2
Largos Normales:	6, 7 y 8 m.
Extremos:	Lisos de máquina.

Sección Perfil Ohm

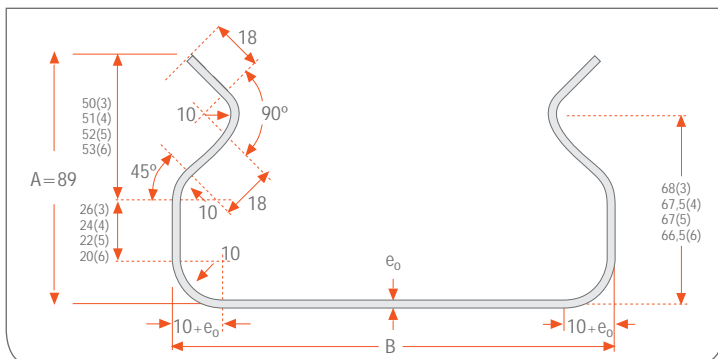

Perfil	Dimensiones nominales		Peso	SAP		
	P. Comp.	Alt.		6 m	7 m	8 m
	Ancho (B)	Eo	P			
	mm	mm	kg/m			
Ohm 150x3	150	3	7,97	43000157	43000190	43000191
Ohm 150x4	150	4	10,56	43000148	43000172	43000173
Ohm 150x5	150	5	13,1	43000149	43000174	43000175
Ohm 200x3	200	3	9,15	43000158	43000192	43000193
Ohm 200x4	200	4	12,13	43000150	43000176	43000177
Ohm 200x5	200	5	15,08	43000151	43000178	43000179
Ohm 200x6	200	6	18,00	43000152	43000180	43000181
Ohm 225x4	225	4	12,91	43000153	43000182	43000183
Ohm 225x5	225	5	16,06	43000154	43000184	43000185
Ohm 225x6	225	6	19,17	43000155	43000186	43000187

Perfiles Tubest

Especificaciones Generales

Tolerancias:	ET-16/MA-7-2
Extremos:	Lisos de máquina.

Sección Perfiles Tubest

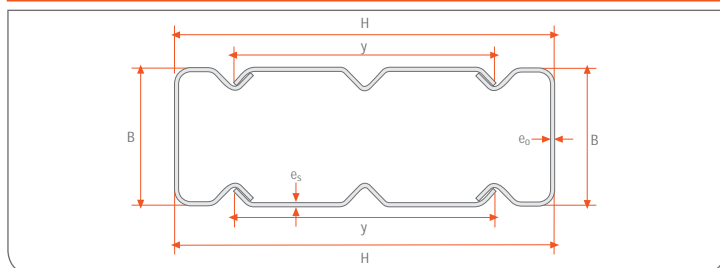

Se pueden fabricar Tubest con ancho (B) hasta 400mm. En caso de requerirse, solicitar a Cintac mayor información.

Perfil	Peso p kg/m
250x150x4x3	27,3
250x200x4x3	30,4
250x200x5x3	36,3
250x200x6x3	42,2
250x225x4x3	32
250x225x5x3	38,3
250x225x6x3	44,5
300x150x3x3	25,4
300x150x4x3	30,5
300x200x3x3	27,7
300x200x4x3	33,6
300x200x5x3	39,5
300x200x6x3	45,4
300x225x4x3	35,2
300x225x5x3	41,5
300x225x6x3	47,7
350x150x3x3	27,7
350x150x4x3	32,8
350x200x3x3	30
350x200x4x3	36
350x200x5x3	41,9
350x200x6x3	47,7
350x225x4x3	37,6
350x225x5x3	43,8
350x225x6x3	50,1
400x150x3x3	30
400x150x4x3	35,2
400x200x3x3	32,4
400x200x4x3	38,3
400x200x5x3	44,2
400x200x6x3	50,1
400x225x4x3	39,9
400x225x5x3	46,2
400x225x6x3	52,4



Perfil	Peso p kg/m
450x150x3x3	32,4
450x150x4x3	37,5
450x200x3x3	34,7
450x200x4x3	40,7
450x200x5x3	46,6
450x200x6x3	52,4
450x225x4x3	42,3
450x225x5x3	48,6
450x225x6x3	54,8
500x150x3x3	34,7
500x150x4x3	39,9
500x200x3x3	37,1
500x200x4x3	43
500x200x5x3	48,9
550x225x6x3	59,5
500x200x6x3	54,8
500x225x4x3	44,6
500x225x5x3	50,9
500x225x6x3	57,1
550x150x3x3	37,1
550x150x4x3	42,3
550x200x3x3	39,5
550x200x4x3	45,5
550x200x5x3	51,4
550x200x6x3	57,2
550x225x4x3	47,0
550x225x5x3	53,3
550x225x6x3	59,5

## Perfiles Tubest One

### Especificaciones Generales

<b>Tolerancias:</b>	ET-16/MA-7-2
<b>Largos Normales:</b>	12 m
<b>Extremos:</b>	Líisos de máquina.

Otras dimensiones: a pedido previa consulta a Cintac.

Perfil	Peso p kg/m	SAP
300x150x4	29,8	36007266
300x200x4	32,9	36007267
350x150x4	32,9	36007268
350x200x4	36,1	36007280
400x150x4	36,1	36007333
400x200x4	39,2	36006652
450x150x4	39,2	36007922
450x200x4	42,4	36007334
500x200x4	45,5	36007319

### Sección Perfiles Tubest One

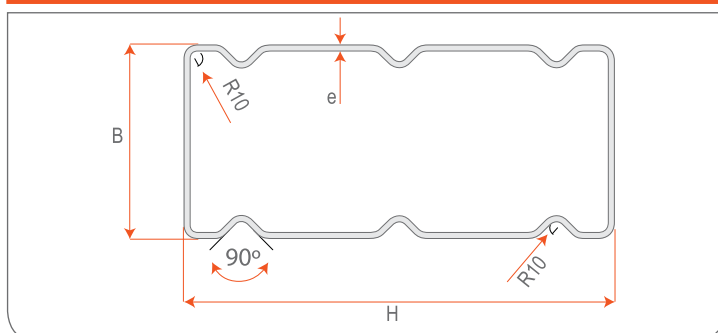

Serie de Perfiles Sigma C

Especificaciones Generales

Tolerancias:	ET-16/MA-7-2
Largos Normales:	6,7 y 8 m
Extremos:	Lisos de máquina.

Otras dimensiones: a pedido previa consulta a Cintac.

Perfil	Peso p kg/m	SAP		
		6 m	7 m	8 m
Sigma C 200X50X3,00	7,39	43000062	43000094	43000095
Sigma C 250X75X3,00	9,74	43000068	43000106	43000107
Sigma C 300X75X3,00	10,90	43000074	43000118	43000119

Sección Perfiles Sigma C

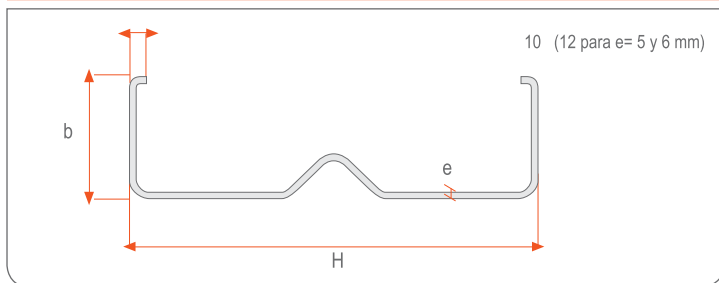

Serie de Perfiles Tubest C

Especificaciones Generales

Tolerancias:	ET-16/MA-7-2
Largos Normales:	6,7 y 8 m
Extremos:	Lisos de máquina.

Otras dimensiones: a pedido previa consulta a Cintac.

Dimensiones nominales			Peso p kg/m	SAP		
h	B	e		6 m	7 m	8 m
mm	mm	mm	kg/m			
200	100	3	14,8	43000072	43000114	43000115
250	150	3	19,5	43000083	43000135	43000136
300	150	3	21,8	43000087	43000141	43000142

Sección Perfiles Tubest C

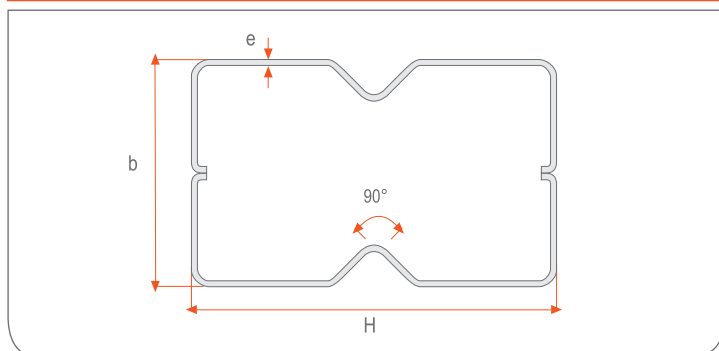

## Serie de Perfil Costanera Z

### Especificaciones Generales

<b>Tolerancias:</b>	ET-16/MA-7-2
<b>Largos Normales:</b>	6 m
<b>Extremos:</b>	Líisos de máquina.

Otras dimensiones: a pedido previa consulta a Cintac.

Perfil	Peso $p$ kg/m
Z Tubest 100x50x15x1,6	2,74
Z Tubest 100x50x15x2,0	3,42
Z Tubest 100x50x15x2,5	4,22
Z Tubest 100x50x15x3,0	5,04
Z Tubest 125x50x15x1,6	3,06
Z Tubest 125x50x15x2,0	3,81
Z Tubest 125x50x15x2,5	4,71
Z Tubest 125x50x15x3,0	5,62
Z Tubest 150x50x15x1,6	3,37
Z Tubest 150x50x15x2,0	4,20
Z Tubest 150x50x15x2,5	5,20
Z Tubest 150x50x15x3,0	6,21
Z Tubest 175x75x20x1,6	4,44
Z Tubest 175x75x20x2,0	5,54
Z Tubest 175x75x20x2,5	6,87
Z Tubest 175x75x20x3,0	8,22
Z Tubest 200x75x20x1,6	4,75
Z Tubest 200x75x20x2,0	5,93
Z Tubest 200x75x20x2,5	7,36
Z Tubest 200x75x20x3,0	8,80
Z Tubest 250x75x20x1,6	5,38
Z Tubest 250x75x20x2,0	6,71
Z Tubest 250x75x20x3,0	9,98

### Sección Perfil Costanera Z

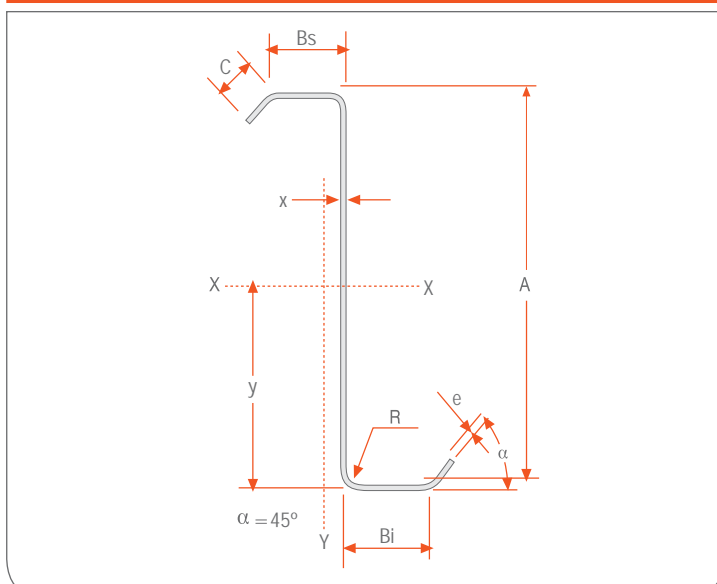

Consulte por Perfiles Costanera Z galvanizados.

### Toledana prepintada y ZincAlum®

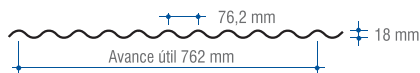

<b>Espesores (mm)</b>	0.30, 0.35 mm estándar y 0.4 mm a pedido.
<b>Longitud planchas</b>	Estándar: 3660 mm. Largos variables: de 1,5 m hasta 9,0 m. Largos superiores sujetos a consulta.
<b>Terminación</b>	Prepintada y ZincAlum®

### 5V



<b>Espesores Nominal</b>	0,30, 0,35 mm estándar y 0,4 mm a pedido.
<b>Longitud Planchas</b>	Estándar: 3500 mm. Largos variables: de 2,0 m hasta 5,0 m Largos superiores sujetos a consulta.
<b>Terminación</b>	ZincAlum®

### Duraplancha



<b>Espesores (mm)</b>	0,35 - 0,4 mm
<b>Largos variables</b>	Desde 2,0 m hasta 9 m

### Teja Continua Curva



<b>Espesor (mm)</b>	0,4 mm
<b>Pendiente mínima</b>	15 %
<b>Terminación</b>	Prepintado

Largos variables de 2,0 m hasta 6,0 m. Largos superiores sujetos a consulta.

### Teja Continua Colonial



<b>Espesor (mm)</b>	0,4 mm
<b>Pendiente mínima</b>	15 %
<b>Terminación</b>	Prepintado / con Aquastop

Largos variables de 2,0 m hasta 6,0 m. Largos superiores sujetos a consulta.

**Metalcon® Estructural**

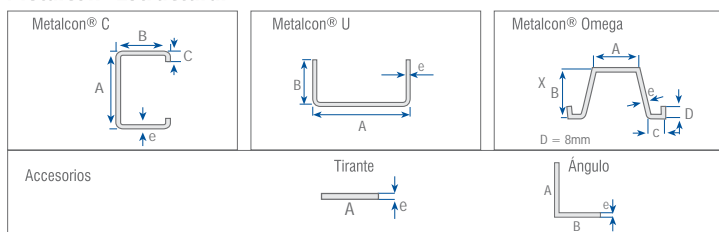

Metalcon® C	Dimensiones				Peso P Kg/m	Largos (ml)	SAP
	A mm	B mm	C mm	e mm			
METALCON® C 2x2x0,85	40	38	8	0,85	0,83	6,00	36000011
METALCON® C 2x3x0,85	60	38	6	0,85	0,96	2,40	36000022
METALCON® C 2x3x0,85	60	38	6	0,85	0,96	4,00	36000023
METALCON® C 2x3x0,85	60	38	6	0,85	0,96	6,00	36000007
METALCON® C 2x4x0,85 p	90	38	12	0,85	1,23	2,50	36000024
METALCON® C 2x4x0,85 p	90	38	12	0,85	1,23	3,00	36000025
METALCON® C 2x4x0,85 p	90	38	12	0,85	1,23	6,00	36000008
METALCON® C 2x4x0,85	90	38	12	0,85	1,23	4,00	36000026
METALCON® C 2x4x0,85	90	38	12	0,85	1,23	6,00	36000012
METALCON® 2x4x1,0 p	90	38	12	1,00	1,44	6,00	36000009
METALCON® C 2x5x0,85 p	100	40	12	0,85	1,32	6,00	36000010
METALCON® C 2x6x0,85	150	40	12	0,85	1,64	6,00	36000013
METALCON® C 2x6x1,0	150	40	12	1,00	1,94	4,00	36000027
METALCON® C 2x6x1,0	150	40	12	1,00	1,94	6,00	36000014
METALCON® C 2x6x1,6	150	40	12	1,60	3,06	6,00	36000015
METALCON® C 2x8x1,6	200	40	12	1,60	3,67	6,00	36000109

p: Perforado (para pasar canalizaciones)

Metalcon® U	Dimensiones				Peso P Kg/m	Largos (ml)	SAP
	A mm	B mm	C mm	e mm			
METALCON® U 2x2x0.85	42	25	-	0,85	0,58	6,0	36000016
METALCON® U 2x3x0.85	62	25	-	0,85	0,72	3,0	36000028
METALCON® U 2x3x0.85	62	25	-	0,85	0,72	6,0	36000017
METALCON® U 2x4x0.85	92	30	-	0,85	1,00	3,0	36000029
METALCON® U 2x4x0.85	92	30	-	0,85	1,00	6,0	36000018
METALCON® U 2x4x1,0	92	30	-	1,00	1,17	6,0	36000110
METALCON® U 2x5x0.85	103	30	-	0,85	1,06	6,0	36000111
METALCON® U 2x5x1,0	103	30	-	1,00	1,25	6,0	36000112
METALCON® U 2x6x1,0	153	30	-	1,00	1,65	4,0	36000030
METALCON® U 2x6x1,0	153	30	-	1,00	1,65	6,0	36000019
METALCON® U 2x8x1,0	203	30	-	1,00	2,04	6,0	36000113

Accesorios	Dimensiones				Peso P Kg/m	Largos (ml)	SAP
	A mm	B mm	C mm	e mm			
METALCON® Tirante 50x0.85	50	-	-	0,85	0,33	en rollos de 60m	36000347
METALCON® Tirante 70x0.85	70	-	-	0,85	0,46	en rollos de 60m	36000346
METALCON® Tirante 100x 0.85	100	-	-	0,85	0,67	en rollos de 60m	36000098
METALCON® Tirante 70x1,6	70	-	-	1,6	0,88	en rollos de 60m	36000097
METALCON® Tirante Gusset 286x1.6	286	-	-	1,6	3,59	3,0	36000099
METALCON® Ángulo 35x35x0,85	35	35	-	0,85	0,46	6,00	36000114
METALCON® Ángulo 190x40x1,0	190	40	-	1,00	1,78	4,00	36000105
METALCON® Ángulo 60x40x0,85	60	40	-	0,85	0,66	6,00	36000115

Producto disponible a pedido y lote mínimo.

## Metalcon® Estructural

Metalcon® Omega	Dimensiones				Peso P	Largos (ml)	SAP
	A mm	B mm	C mm	e mm	Kg/m		
METALCON® Omega Normal	38	35	15	0,85	<b>0,98</b>	3,00	36000031
METALCON® Omega Normal	38	35	15	0,85	<b>0,98</b>	6,00	36000021
METALCON® Omega Económica	38	35	15	0,5	<b>0,59</b>	6,00	36000020

## Metalcon® Tabiques

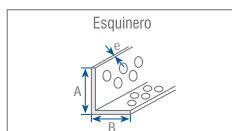
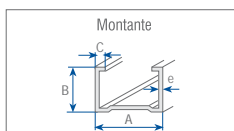
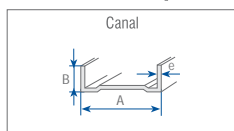

Metalcon® Tabiques	Dimensiones				Peso P	Largos (m)	SAP
	A mm	B mm	C mm	e mm	Kg/m		
Montante Normal P	60	38	6	0,50	<b>0,56</b>	2,40	36000034
Montante Normal P	60	38	6	0,50	<b>0,56</b>	3,00	36000035
Montante Económico	38	38	5	0,50	<b>0,48</b>	2,40	36000032
Montante Económico	38	38	5	0,50	<b>0,48</b>	3,00	36000033
Canal Normal	61	20	-	0,50	<b>0,39</b>	2,40	36000198
Canal Normal	61	20	-	0,50	<b>0,39</b>	3,00	36000037
Canal Económico	39	20	-	0,50	<b>0,31</b>	2,40	36000197
Canal Económico	39	20	-	0,50	<b>0,31</b>	3,00	36000036
Esquinero Perforado	30	30	-	-	<b>0,18</b>	2,40	36000002
Esquinero Perforado Económico	25	25	-	-	<b>0,15</b>	3,00	36000107

Metalcon® Tabiques	Dimensiones				Peso P	Largos (ml)	SAP
	A mm	B mm	C mm	e mm	Kg/m		
Montante Especial P	45	38	6	0,50	<b>0,50</b>	2,40	36000185
Montante Básico	31	38	5	0,50	<b>0,45</b>	2,40	36000169
Canal Especial	46	20	-	0,50	<b>0,33</b>	3,00	36000199
Canal Básico	32	20	-	0,50	<b>0,28</b>	3,00	36000196

Producto disponible a pedido y lote mínimo.

**Metalcon Cielos**

**Portante 40 R®**

Uso:

- Confección de cielo raso, como soporte de placa.

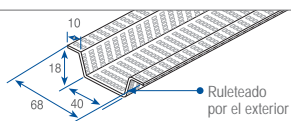

Nomenclatura	A (mm)	B (mm)	C (mm)	Espesor (mm)	Peso (kg/m)	Largos (ml)	SAP
40x18x10x0,5	40	18	10	0,50	0,38	3,00	36000005
40x18x10x0,5	40	18	10	0,50	0,38	6,00	36000004

**Perfil AT®**

Usos:

- Permite fijar el nivel para estructuras de cielo raso.
- Prolongación de cuerda inferior de la cercha o larguero.

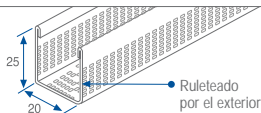

Nomenclatura	A (mm)	B (mm)	C (mm)	Espesor (mm)	Peso (kg/m)	Largos (ml)	SAP
20x25x4x0,42	20	25	4	0,42	0,25	3,00	36000006

**Conector TI®**

Uso:

- Conector nivelador de la cuerda inferior o larguero directamente a la cercha, losa o costanera.

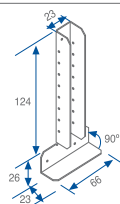

Nomenclatura	Unidades	SAP
150x66x0,85	Caja (100 Unid.)	36000050
150x66x0,85	Caja (10 Unid.)	36000100

**Recomendaciones para Estructura de Cielo**

Espesor placa Yeso - Cartón (mm)	Alternativas de luces entre elementos		
	Cerchas (cm)	Conector TI® (cm)	Portante 40R® (cm)
10 ó 12, 5 ó 15	Luces hasta 150	Luz máxima 100	40



**PV - 4°**



<b>Espesores (mm)</b>	0,4 - 0,5 - 0,6 - 0,8
<b>Largos variables</b>	De 1,5 m hasta 14 m, según espesor del panel.

**PV - 6°**

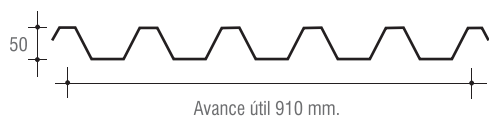

<b>Espesores (mm)</b>	0,4 - 0,5 - 0,6 - 0,8
<b>Largos variables</b>	De 1,5 m hasta 14 m, según espesor del panel.

**PV - 7**



<b>Espesores (mm)</b>	0,4 - 0,5
<b>Largos variables</b>	Desde 2,0 m hasta 9 m.

**PV - 8**

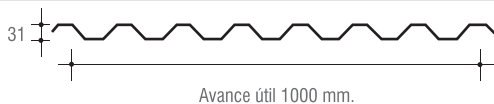

<b>Espesores (mm)</b>	0,4 - 0,5 - 0,6 - 0,8
<b>Largos variables</b>	Desde 1,5 m. hasta 15 m.

Acrylit



Espeores (mm)	1,4
Largo	11,8 m.

A-2 / KR-24

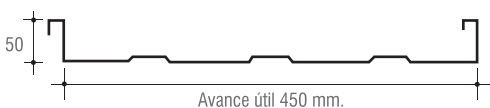

Espeores (mm)	0,4 - 0,5 - 0,6
Largos variables	De 2,0 m hasta 14 m, según espesor del panel.

Nota: Opción fabricación en terreno (consulte por disponibilidad de máquina conformadora).

KR - 18



Espeores (mm)	0,4 - 0,5 - 0,6
---------------	-----------------

Nota: Fabricación en terreno (consulte por disponibilidad de máquina conformadora).

Paneles perforados

Diámetro perforación	4 mm - 5 mm
Aplicable a	PV4, PV6, Pit, Ondulado 48, PV8, A2.
Área perforada	22 %

Largos variables: de 1,5 m hasta 15 m. Para largos superiores, consulte a Cintac.

**PIT**

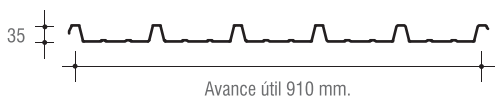

<b>Espesores (mm)</b>	0,4 - 0,5 - 0,6 - 0,8
<b>Largos variables</b>	De 1,5 m hasta 15 m, según espesor del panel.

**Cubiertas anticondensantes con Aquastop**

Sistema que resuelve el problema de la condensación en cubiertas y revestimientos de acero.

<b>Aplicable a</b>	PV-4, PV-6, KR-24, KR-18, A-2.
<b>Usos</b>	Bodegas, estacionamientos y servicentros. Proyectos industriales, garajes, hangares, criaderos de animales, etc.

**Paneles curvos y contracurvos**

<b>Aplicable a</b>	<b>Curvas y Contracurvas:</b> PV-4 - PV-6 <b>Curvas:</b> Pit
<b>Largos variables</b>	El largo mínimo del panel es de 1,5 m. y el máximo 12,0 m.
<b>Usos</b>	Cubiertas, Revestimientos y Hombro Curvo

**Ondulado 48**

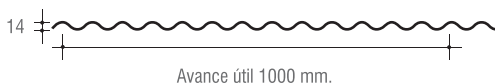

<b>Espesores (mm)</b>	0,4 - 0,5 - 0,6 - 0,8
<b>Largos variables</b>	De 2,0 m hasta 15 m, según espesor del panel.

**Isopol**

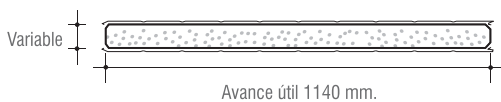

<b>Espesores (mm)</b>	50 - 75 - 100 - 120 - 150 - 200 - 250
<b>Largos variables</b>	De 2,50 m hasta 15,0 m. (excepto 200 y 250 mm de máx. 13,0 m), largos superiores sujetos a consulta.

**Kover Pol**

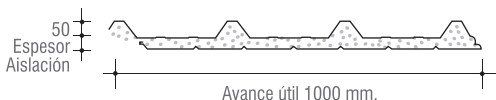

<b>Espesores (mm)</b>	50 - 75 - 100 - 150 - 200
<b>Largos variables</b>	Desde 2,5 m hasta 15 m, excepto Koverpol 200/250 de máx 13,0 m), largos superiores sujetos a consulta.

**E - Kover Pol**

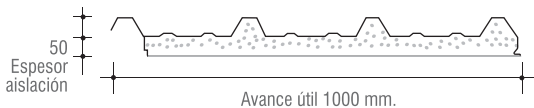

<b>Espesores (mm)</b>	50 - 75 - 100 - 150 - 200
<b>Largos variables</b>	Desde 2,5 m. hasta 12 m.

**E - Kover Pur L-804**

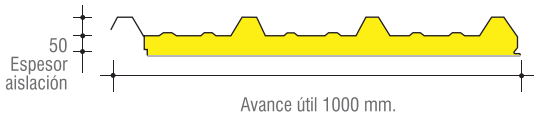

<b>Espesores (mm)</b>	30 - 50 - 80
<b>Largos variables</b>	Desde 3,0 m. hasta 12 m.

**Isopur**



<b>Espesores (mm)</b>	50 - 80 - 100 - 120 - 150
<b>Largos variables</b>	Desde 2,5 m hasta 12 m, según espesor del panel.

**Isowall®**

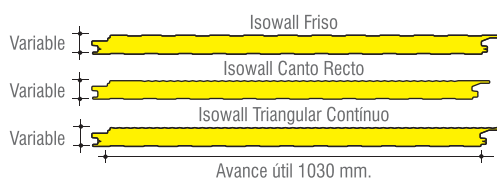

<b>Espesores (mm)</b>	50 - 75 - 100
<b>Largos variables</b>	De 2,5 m hasta 14 m, largos superiores sujetos a consulta.

**Kover L-804**

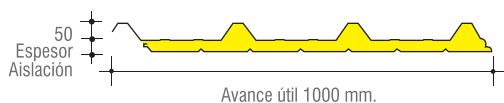

<b>Espesores (mm)</b>	30 - 50 - 80
<b>Largos variables</b>	De 2,5 m hasta 12 m, según espesor del panel.

**Kover L-806**

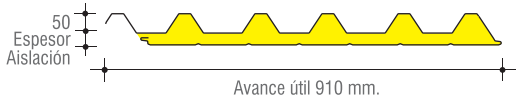

<b>Espesores (mm)</b>	30 - 50 - 80
<b>Largos variables</b>	De 2,5 m hasta 12 m, según espesor del panel.

**Kover Lana**

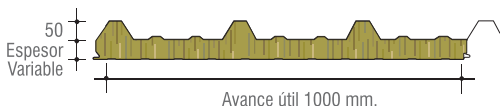

<b>Espesores (mm)</b>	40 - 50 - 80 - 100 - 125 - 150
<b>Largos variables</b>	De 2,5 m hasta 12 m (El largo máximo recomendado por la condición de transporte y manipulación para los paneles de espesor 125 y 150 mm es de 8 m).

**Iso Lana**

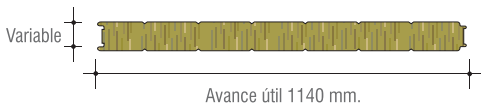

<b>Espesores (mm)</b>	40 - 50 - 80 - 100 - 125 - 150
<b>Largos variables</b>	De 2,5 m hasta 12 m (El largo máximo recomendado por la condición de transporte y manipulación para los paneles de espesor 125 y 150 mm es de 8 m).

### Isolana Acústico

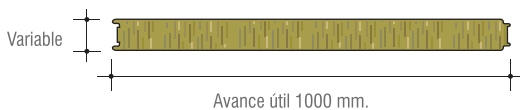

<b>Espesores (mm)</b>	50 - 80 - 100
<b>Largos variables</b>	Planchas de 5,95 m.
<b>Color</b>	RAL 9002

### Placa Colaborante Intadeck

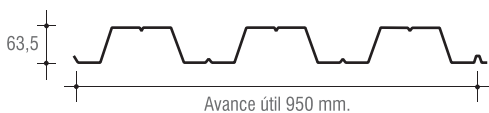

<b>Espesores (mm)</b>	0,8 - 1,0 (Sujeto a consulta)
<b>Largos variables</b>	Desde 1,5 m. hasta 15 m. Largos superiores sujetos a consulta.

### Placa Colaborante PV3-RX\*

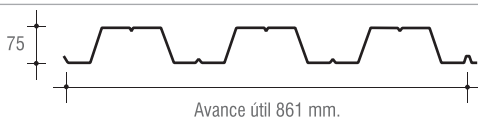

<b>Espesores (mm)</b>	0,8 - 1,0
<b>Largos variables</b>	Desde 1,5 m. hasta 14 m.

\* Disponibilidad de producto Placa Colaborante PV3-RX, sujeto a proyecto sobre 3.000 m2.

- Largos superiores sujetos a consulta.
- Todas las dimensiones son nominales y sujetas a tolerancias de fabricación y criterios normativos.
- Mínimos de fabricación sujetos a consulta.

# CINTAC®

## **CASA MATRIZ:**

Camino a Melipilla 8920 - Maipú, Santiago.  
Tel.: (56) 22 484 9200

## **LAS CONDES DESIGN:**

Av. Las Condes 9765, local 210  
Las Condes, Santiago.

## **ANTOFAGASTA:**

Acantatita 424, Sector La Chimba  
Tel.: (56) 9 9332 0258 / (56) 9 9346 1584

## **CONCEPCIÓN:**

Camino a Coronel 5580 - km 10, Bodega  
6-B, Megacentro San Pedro de la Paz.  
Tel.: (56) 41 246 1620 / (56) 9 9352 9676

